

PURE20

SYSTEMS



PURE20
A BRAND OF **ionic**

PURE20



Certified Resins

**THATCHAM
FMVSS-208
Tested**

WELCOME TO THE MEG OHM

The Pure20™ van-mount range has undergone a complete ground up revision resulting in an impressive 10% weight reduction for improved payload capacity as well as a 100mm lower centre of gravity for improved vehicle handling. In addition the Pure20™ range boasts tech options to improve filter performance, RO membrane life and water quality worthy of the Greek Sea Gods whose names they bear. With new tech such as periodic auto-flush, ROMS™ and PDI™, Pure20™ water quality moves into the sub zero ppm range.

Window Cleaners are learning more about the spot free benefits of cleaning windows with ultra pure water measured in the meg Ω range and Pure20™ is taking its place as a premium brand manufacturer. With a 10year stainless steel chassis warranty, FMVSS-208 crash tested design and a host of meg Ω tech Pure20™ represents the best value for money truck-mount systems in the market.

ROMS™ – Reverse Osmosis Maintenance System. At the end of each tank fill, pure water is diverted to the RO membrane housing. Leaving the RO membrane bathing in pure water between fills ensures that dissolved solids (found in tap water) do not foul the membrane. Further, dissolved solids that are not removed from the membrane surface during Periodic Auto Flush cycles are absorbed by the pure water during the 'rest period' to be flushed away during the first flush on startup.

PDI™ – Perpetual De-ionisation. This feature considerably extends DI resin contact time. Ultra purification is achieved by repeated exposure of purified water to the final DI polishing stage.



PURE20 OVERVIEW

TANK SIGHT GAUGE

Fast and accurate view of the water level in the tank.

DUAL TDS MONITORING

Water quality is measured at critical stages.

DIGITAL FLOW CONTROL

Auto-compensating digital flow control allows precise operation of the pumps.

4040 REVERSE OSMOSIS

In hi-performance stainless steel housing.

STAINLESS STEEL CHASSIS

Covered by our 10-year warranty.



FULLY BAFFLED TANK

Black polypropylene tank with advanced baffling for increased vehicle stability.

VARIABLE PUMP CONTROL

Variable speed, auto-compensating flow control.

TWIN 12V DELIVERY PUMPS

Each pump may be activated remotely, using the key fob.

RE-FILLABLE DI VESSEL

Polishes water to zero parts per million

10" 5 MICRON SEDIMENT FILTER

Removes impurities larger than 5 Microns.

10" CARBON FILTER

Removes Chlorine, protects RO membrane.

The stainless steel chassis, along with any stainless steel filters are covered by our 10-year warranty

THE MEG Ω DIFFERENCE

The Meg Ω is a small unit of measure, but ultra pure water in the Meg Ω range delivers faster, better spot free results. You can and your customers can see with their eyes.

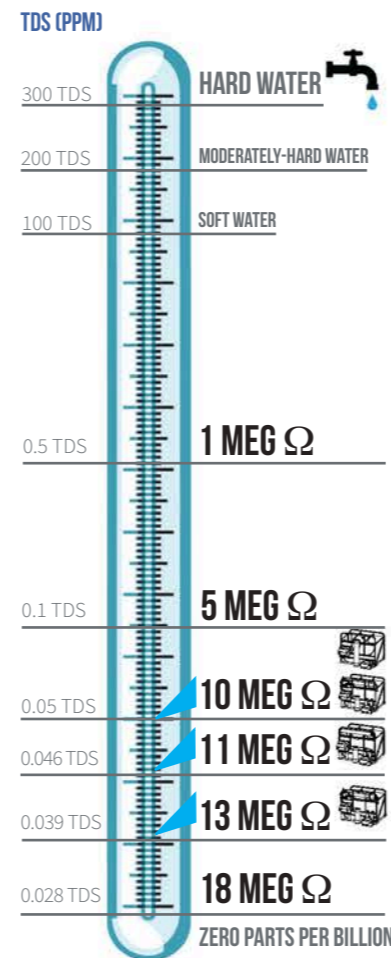

PURE20 CONFIGURATIONS

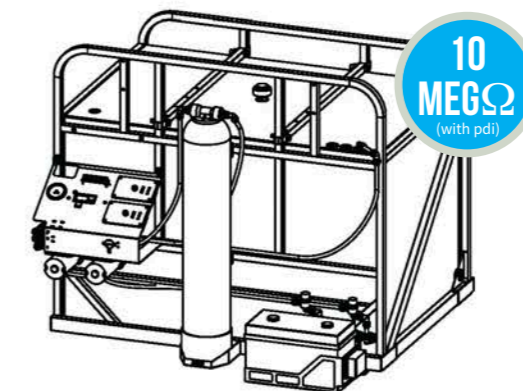

HYDROS™

Hydros™ is Pure20's cold pure water van-mount delivery system. Designed for quick pure water filling from a static water treatment system or emergency filling from a mains water supply.

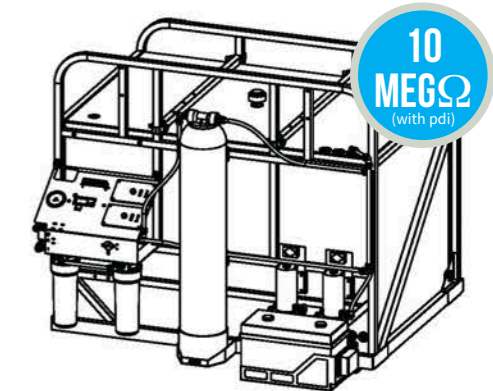

PROTEUS™

Proteus™ is a three-stage DI system for use in soft water areas such as Scotland & Wales with mains water quality <50ppm. Proteus can also be used as a higher-grade delivery system in conjunction with static systems.

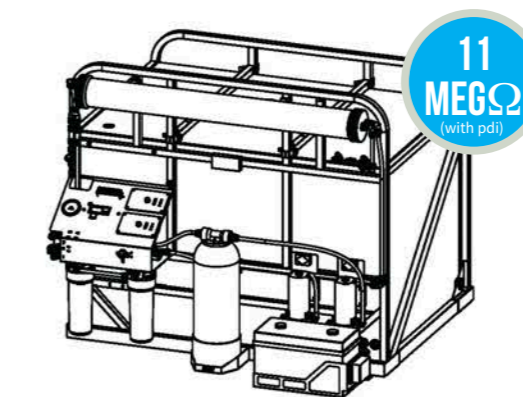

TRITON™

Triton™ is a high performance, manual fill, full five-stage RO/DI system. Fully automated fill with PFS™, ROMS™, & PDI™ is available as an optional extra.

See full specification on reverse

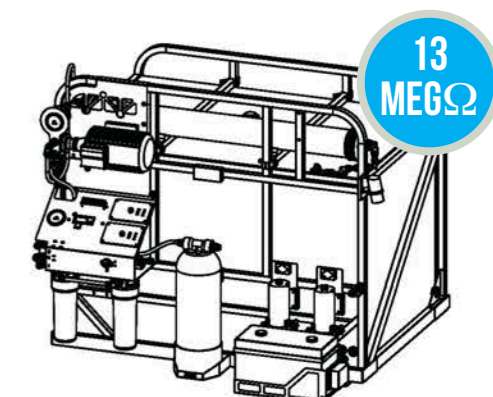

TITAN™

Titan™ is Pure20's top of the range, fully automatic five-stage RO/DI system with 240v mains powered boosted fill, PFS™, ROMS™, & PDI™ are all standard features on the Titan™.



AS STANDARD...

Heavy Duty Stainless Steel, fully Welded, Crash-test Certified Component Chassis to FMVSS-208 Standard.

FMVSS-208 Cast Mounting Brackets

Remote Pump Control

Hi-Density Polypropylene Spark Tested Baffled Tank

Automatic Fill Shut Off

Auto-compensating Pump Flow Control

Optional Rear Suspension Upgrade (for load levelling)

THATCHAM
FMVSS-208
Tested





In-line water softeners are highly recommended for use in hard water areas. Visit pure2o.co.uk/hardwatermaps to find out if a water softener is recommended for your Pure2o™ machine.



Ionic Water Softeners with WQA certified Resins

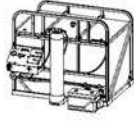
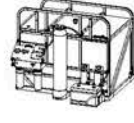

	Capacity in Ltrs	Variable Pump Control	Single 12v Delivery Pump	Twin 12v Delivery Pumps	110 amp 12v battery	Dual TDS Meter	835 DI Filter	6.18 DI Filter	10" Carbon Filter	10" Sediment Filter	Pressure Gauge	4040 RO Filter	PFS™	ROMS™	PDI™	240v Boost Pump	Split Charger
HYDROS™ 	300	●	●	○	○	○	○	●							○		○
	400	●	●	○	○	○	○	●							○		○
	500	●	●	○	○	○	○	●							○		○
	600	●		●	●	○	○	●							○		○
	700	●		●	●	○	○	●							○		○
	800	●		●	●	○	○	●							○		○
	900	●		●	●	○	○	●							○		○
PROTEUS™ 	300	●	●	○	○	○	○	●	●	●					○		○
	400	●	●	○	○	○	○	●	●	●					○		○
	500	●	●	○	○	○	○	●	●	●					○		○
	600	●		●	●	○	○	●	●	●					○		○
	700	●		●	●	○	○	●	●	●					○		○
	800	●		●	●	○	○	●	●	●					○		○
	900	●		●	●	○	○	●	●	●					○		○
TRITON™ 	300	●	●	○	○	●		●	●	●	●	○			○		○
	400	●	●	○	○	●		●	●	●	●	○			○		○
	500	●	●	○	○	●		●	●	●	●	○			○		○
	600	●		●	●	○		●	●	●	●	○			○		○
	700	●		●	●	○		●	●	●	●	○			○		○
	800	●		●	●	○		●	●	●	●	○			○		○
	900	●		●	●	○		●	●	●	●	○			○		○
TITAN™ 	300	●	●	○	○	●		●	●	●	●	●	●	●	●	●	○
	400	●	●	○	○	●		●	●	●	●	●	●	●	●	●	○
	500	●	●	○	○	●		●	●	●	●	●	●	●	●	●	○
	600	●		●	●	○		●	●	●	●	●	●	●	●	●	○
	700	●		●	●	○		○	●	●	●	●	●	●	●	●	○
	800	●		●	●	○		○	●	●	●	●	●	●	●	●	○
	900	●		●	●	○		○	●	●	●	●	●	●	●	●	○

MACHINE DIMENSIONS (ALL VARIANTS)

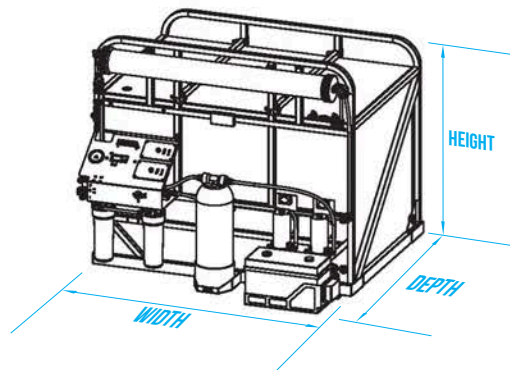

TANK CAPACITY	HEIGHT (mm)	WIDTH (mm)	DEPTH (mm)
300 Litres	1062	1129	931
400 Litres	1062	1129	931
500 Litres	1062	1224	1166
600 Litres	1062	1224	1166
700 Litres	1062	1224	1166
800 Litres	1062	1224	1321
900 Litres	1062	1224	1321
1,000 Litres	1062	1224	1321



Pure2o Ltd, Westergate, Hillmead Enterprise Park

Swindon, Wiltshire, SN5 5WN

Telephone: (01793) 871 386

E-mail: info@pure2o.co.uk

www.pure2o.co.uk

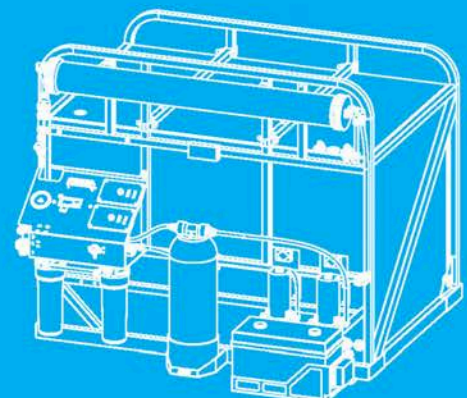

The logo for PURE20, featuring the word 'PURE' in a white, bold, sans-serif font, followed by '20' in a dark blue, bold, sans-serif font. Below this, the text 'A BRAND OF' is written in a small, white, sans-serif font, followed by the 'ionic' logo in a white, lowercase, sans-serif font.

PURE₂₀
A BRAND OF **ionic**

The background of the entire image is a light blue color with a faint, white line-art illustration of industrial machinery, including pipes, tanks, and structural frames, overlaid on the background.

pure20.co.uk

PURE₂₀ SYSTEMS



PURE2O THE VALUE BRAND OF IONIC SYSTEMS

When Ionic introduced the world famous Reach & Wash® System back in 1997, it revolutionised the way window cleaners work. Now, using waterfed poles, window cleaners are able to work higher, faster and safer than ever possible before. Ionic even instituted it's own crash-testing programme at **Thatcham Research** to make sure that Reach & Wash® systems were safe to transport and would not pose a danger to drivers or passengers.

We believe that no one should have to compromise safety in order to take advantage of the benefits of using waterfed pole systems for window cleaning.

For this reason, Ionic established Pure2o as a practical, no-nonsense brand. Pure2o Systems have the same crash-tested chassis and installation as Ionic's Reach & Wash® systems, and Pure2o even has it's own FMVSS-208 compliance certificate from Thatcham Research.



For technical specifications visit our website where you can download and/or print the data sheet. Scan the QR code or visit:

www.pure2o.co.uk

- PURE2O SYSTEMS -

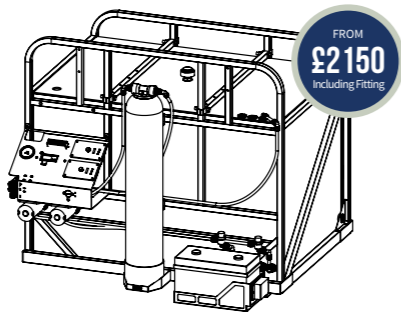

HYDROS™

Hydros™ is Pure2o's cold pure water van-mount delivery system. Designed for quick pure water filling from a static water treatment system or emergency filling from a mains water supply.

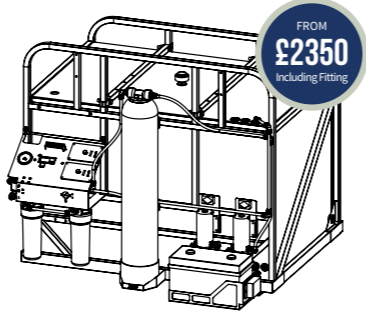

PROTEUS™

Proteus™ is a three-stage DI system for use in soft water areas such as Scotland & Wales with mains water quality <50ppm. Proteus can also be used as a higher-grade delivery system in conjunction with static systems.

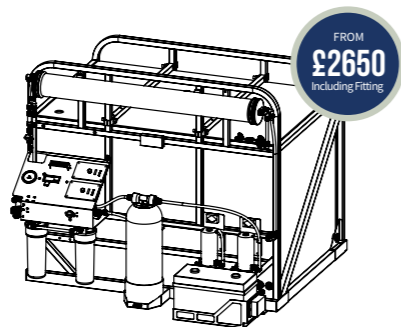

TRITON™

Triton™ is a high performance, manual fill, full five-stage RO/DI system. Fully automated fill with PFS™, ROMS™, & PDI™ available as an optional extras.

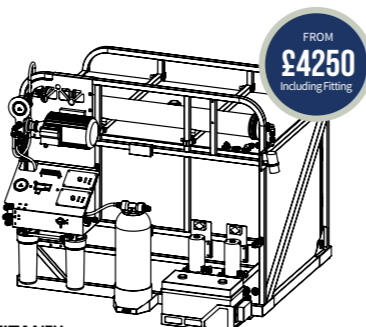

TITAN™

Titan™ is Pure2o's top of the range, fully automatic five-stage RO/DI system with 240v mains powered boosted fill, PFS™, ROMS™, & PDI™ are all standard features on the Titan™.

- PRICE LIST & FINANCE -

Pure2o Hydros™

300 litre	£ 2 150.-
400 litre	£ 2 250.-
500 litre	£ 2 750.-
600 litre	£ 3 150.-
700 litre	£ 3 250.-
800 litre	£ 3 750.-
900 litre	£ 3 850.-
1000 litre	£ 3 950.-

Pure2o Triton™

300 litre	£ 2 650.-
400 litre	£ 2 750.-
500 litre	£ 3 250.-
600 litre	£ 3 650.-
700 litre	£ 3 750.-
800 litre	£ 4 250.-
900 litre	£ 4 350.-
1000 litre	£ 4 450.-

Pure2o Proteus™

300 litre	£ 2 350.-
400 litre	£ 2 450.-
500 litre	£ 2 850.-
600 litre	£ 3 350.-
700 litre	£ 3 450.-
800 litre	£ 3 950.-
900 litre	£ 4 050.-
1000 litre	£ 4 150.-

Pure2o Titan™

300 litre	£ 4 250.-
400 litre	£ 4 350.-
500 litre	£ 4 750.-
600 litre	£ 5 250.-
700 litre	£ 5 350.-
800 litre	£ 5 850.-
900 litre	£ 5 950.-
1000 litre	£ 6 150.-

Upgrades -

PFS+ROMS+PDI	£ 300.-
PDI	£ 100.-
Added Pump & Controller	£ 300.-
25L DI Vessel Upgrade	£ 90.-
Inline TDS	£ 70.-
12V 115aH Battery & Cage	£ 175.-
Bespoke Charging solutions	£ POA.-

PURE2O

www.pure2o.co.uk

PRICE PROMISE

Now you don't have to choose between price and safety. Pure2O offers you both. Put simply, **we'll beat any genuine system quote from a UK supplier.**

Call 01793 871 386 or visit www.pure2o.co.uk for more information



www.pure2o.co.uk

Address: Pure2o Ltd, Westerngate, Hillmead Enterprise Park, Swindon, Wiltshire, SN5 5WN // Phone: +44 (0)1793 871 386

Email: info@pure2o.co.uk // Web: www.pure2o.co.uk